

**FY 2010 Annual Grant Application**  
**Transportation Development Act/*TransNet* Bicycle**  
**and Pedestrian Projects**

**Project:**

**Bike Lockers and Racks**

**Submitted by:**

**City of Escondido**



**FY 2010 Annual Grant Application  
Transportation Development Act/*TransNet* Bicycle and Pedestrian Projects**

Applicant (Agency): City of Escondido

Project Name: Bike Lockers and Racks (Escondido City Hall and Downtown Area)

Application Amount: \$42,034

Project Type: Bicycle Lockers and Racks (Purchase and Installation)

Project Limits: Escondido City Hall and select locations throughout the Downtown Specific Planning Area Business/Retail Core.

**Project Description:** The request involves the installation of bike lockers and new decorative racks at City Hall, and decorative bike racks at various locations throughout the downtown business/retail core (generally along Grand Avenue and side streets).

**Bike Lockers:** There are approximately 300 employees (full and part time) that work at City Hall. A number of employees consistently have ridden bikes to work over the last decade, but more have begun to ride bike over the last few years due to rising gas prices, part of an exercise program, green strategy, or other factors. Now that the Sprinter is operational, some employees use the Sprinter to get to Escondido, and then ride their bikes to City Hall from the Transit Center. Some of these employees also keep an additional bike at the other end of the Sprinter line and ride their bikes home. Employees that ride bikes to City Hall generally bring their bikes into the office and store them in hallways, their personal cubicles or other unused spaces since there are no secured areas to store bikes. Many employees are reluctant to use the existing bike racks around City Hall since they are located in areas that are not under constant surveillance, and the bikes or bike components are more susceptible to theft or vandalism. The proposed number of bike lockers requested would provide space for up to 12 bicycles by utilizing a mix of single and double locker designs. This would fill an existing need for bike lockers at City Hall and also would provide a sufficient number of lockers for any anticipated future demand.

**Bike Racks:** The proposal would provide for up to 12 new bicycle racks to be installed at City hall and throughout the central downtown retail core area. There currently are four bike racks located around City Hall which would be removed and replaced with a more decorative rack to further encourage their use. The existing bike racks are the typical multi-loop galvanized design and these racks would be removed and reused at other City facilities/parks that have a need for additional bike parking. The new racks would include features that either would resemble the City Hall architecture (dome feature) or would be shaped like bicycles. These racks are readily available and do not require a custom order. The concrete pads that support most of the existing racks at City hall will need to be removed and new pads poured in certain areas since the concrete either is severely cracked and/or buckled due to tree roots, inadequately installed concrete, or other factors. The new rack designs do not need to be set in the concrete like the existing racks, but can be bolted onto new pads or onto existing

concrete areas. The new racks also would be placed in more convenient or secure locations.

There are no bicycle racks along the City’s Downtown Business/Retail Core and most bicyclists either chain their bikes to existing street furniture, light or sign poles, or trees. New decorative bike racks are proposed to be installed at various locations along the main downtown retail core that would either carry the architectural theme of City Hall into the downtown area, and/or incorporate other non-standard type racks that would enhance the artistic and historic theme of downtown. Racks purchased would not require custom design orders, but are readily available from various vendors.

**Survey of Other City Facilities:**

City Library and East Valley Community Center: The Escondido Library and East Valley Community Center currently provides bike racks in front of their main entrances. New bike racks currently are being installed as part of the front entry/landscape rehabilitation program at the main library downtown. The City Librarian indicated there currently wasn’t a demand for separate bike lockers or space to install them at the downtown library or the East Valley Community Center.

Public Works Yard: The public works yard is a gated and monitored facility that provides sufficient areas to secure bicycles and other personal items. This facility does not have a need for individual bike lockers or additional bike racks.

**Project Timing:**

The bike lockers and bike racks would be ready to install soon after the grant funds were available. The final locations of the lockers and racks would need to be coordinated with the City’s Appearance Committee and the Escondido Downtown Business Association (DBA). The request already has been reviewed by the Escondido City Council and the City’s Grants Committee.

**SUMMARY OF COST ESTIMATES:**

<b>Funding Sources</b>	<b><u>Revenue Sources</u></b>	<b><u>Amount</u></b>
	TDA/TransNet Claim Amount	<u>\$42,034</u>
		<b>Total</b>

Contact Person: Jay Paul

Title: Associate Planner

Address: 201 N. Broadway, Escondido, CA 92025

---

Phone: (760) 743-0910 Fax: (760) 743-4313

E-mail: jpaul@ci.escondido.ca.us

Person Authorized to Submit Application:

I certify that I have reviewed the Bicycle and Pedestrian Claims Guidelines and the information submitted in this application is accurate and in accordance with these guidelines.

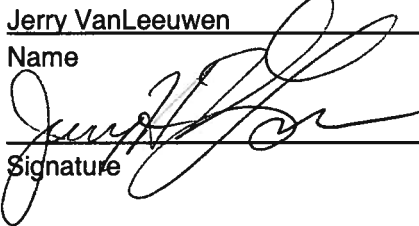
Jerry VanLeeuwen Director of Community Services  
 Name Title  
 May 5, 2009  
 Signature Date

**Project Funding:**

**Total Estimated Project Cost** (Please attach a detailed project estimate based on best available engineering) \$ \$42,034

Revenues (Source and Amount):  
 Matching Funds (Category 9 of Project Selection Criteria)

<u>Revenue Source</u>	<u>Amount</u>
_____	\$ <u>N/A</u>
_____	\$ _____
<b>Total</b>	\$ _____
<b>TDA/TransNet</b> (Application Amount as shown in Category 10 of Project Selection Criteria)	\$ _____
<b>Total Revenues</b>	\$ <u>\$42,034</u>

**Scope of Work**

<b>Deliverables</b>	<b>Completion Date</b>
Grant awarded by SANDAG Board	July 2009
Final locations for the installation of the bike racks and lockers determined (to be reviewed by City Appearance Committee and Downtown Business Association). Project already reviewed and approved by the Escondido City Council and the Grants Committee.	August/Sept. 2009
Request grant funds from SANDAG	August/Sept. 2009
Order racks and lockers	Sept. 2009
Install racks and lockers	Oct/Nov. 2009

# Bicycle Parking Cost Estimates

(Individual item estimates provides from various manufacturers/vendors)

Item	Quant.	Cost	Total
Triangle Shaped or Single Locker (1 bike) <i>(metal with powder coat)</i>	4	\$1,437 base	\$5,748
Perforated door, standard key lock	4	\$140 per door	\$560
Zinc Primer Coat	4	\$200	\$800
Install 2 x 2 hrs. (requires min. 2 workers)	4	\$100 hr.	\$1600
Tax and Shipping			<u>\$952</u>
		Total	\$9,660
2 Bike Locker with metal divider <i>(metal with galv. undercoat)</i>	4	\$1,991 base	\$7,964
Perforated door, standard key lock	4	\$280 per locker	\$1,120
Zinc Primer Coat	4	\$200	\$800
Install 2 x 2 hrs. (requires min. 2 workers)	4	\$100 hr. x 2	\$1,600
Tax and Shipping			<u>\$1,195</u>
		Total	\$12,679
Vintage Bike Rack	6	\$500 ea.	\$3,000
Surface Mount	6	\$40 ea.	\$240
Bike Rack Placard	6	\$50 ea.	\$300
Tax plus Shipping & Handling			\$640
Install 1 x 2 hrs	6	\$100 hr. x 2	<u>\$1,200</u>
		Total	\$5,380
"Bike-Bike" Rack	6	\$490 ea.	\$2,929
Tax plus Shipping & Handling			\$586
Install 1 x 2 hrs	4	\$100 hr. x 2	<u>\$800</u>
		Total	\$4,313
Remove and install new pads (racks)	4	\$1000	\$4,000
Remove and relocate landscaping (lockers)	2	\$1000	\$2,000
Install new pads (lockers)	2	\$1000	<u>\$2,000</u>
		Total	\$8,000
		Sub Total	\$40,032
		5% cont.	\$2,002
		<b>Grand Total</b>	<b>\$42,034</b>

# Bike Racks

"Bike Bike Rack"

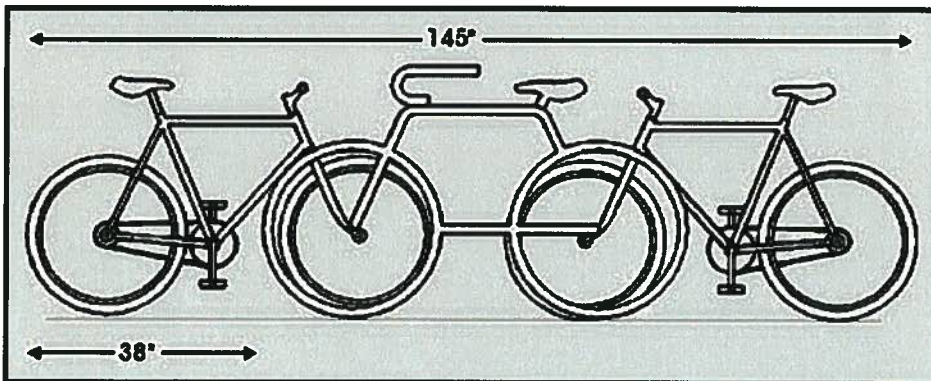
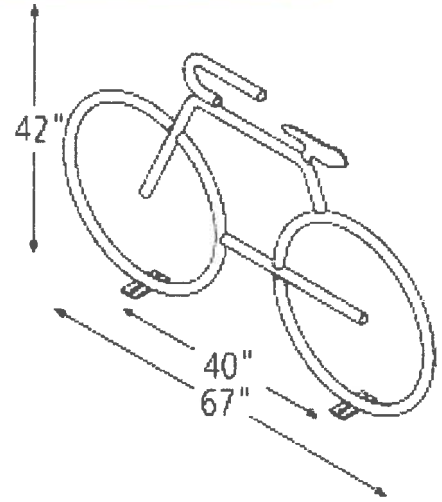



# Vintage Bike Racks

Existing Bike Racks and proposed Vintage Bike Racks to resemble City Dome and other architectural features around the downtown area



Existing bike racks with damaged pads to be removed and used at other City facilities



City Hall Dome Architecture



# Bike Lockers

Last Remaining City Bike Locker



Missing Bike Locker



## Proposed Bike Locker Designs

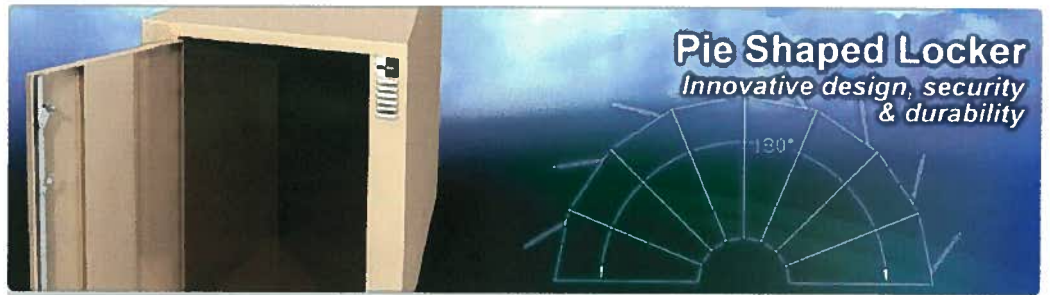



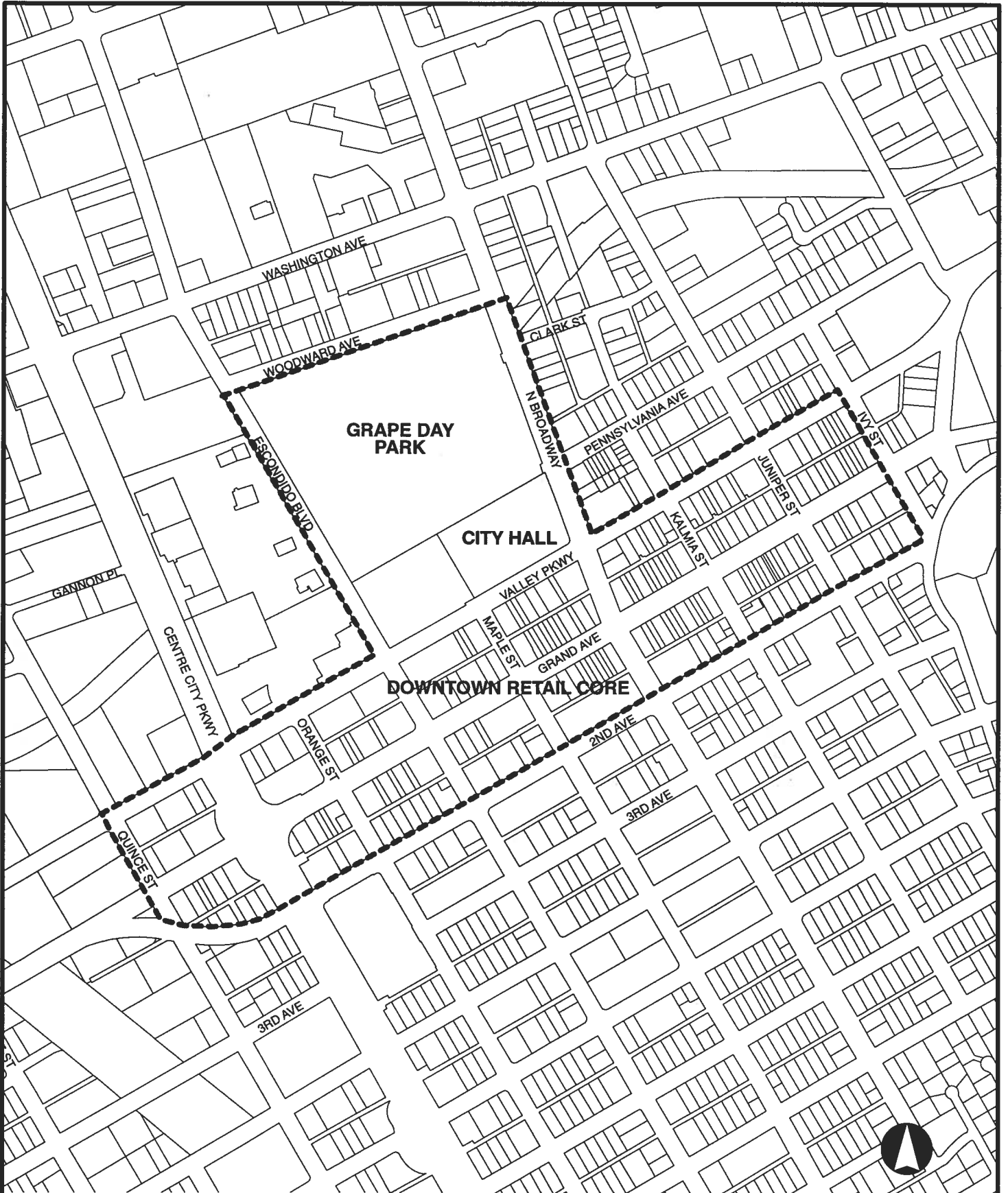

Portions of this DERIVED PRODUCT contains geographic information copyrighted by SanGis. All rights reserved.

# PROPOSED PROJECT BIKE LOCKERS AND RACKS



LOCATION/ZONING